

155

120

50

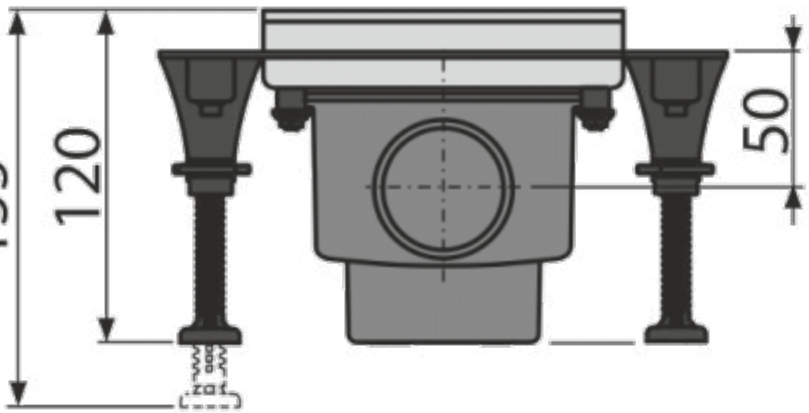

min 105 (15)

Ø50

118

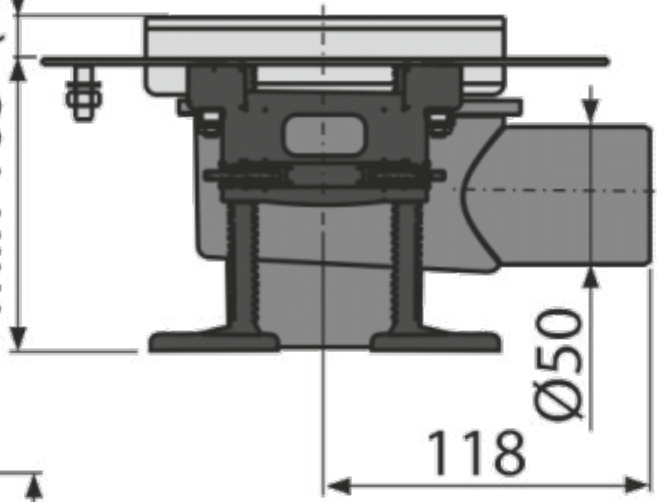

□ 103

□ 130

□ 205

